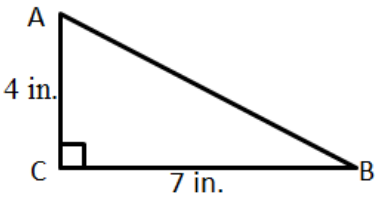

Name: _____

Block: _____

Vocabulary: Sine, cosine, tangent, complements.

	<p>1) Find $\sin A =$</p> <p>2) Find $\tan B =$</p> <p>3) Find $\cos B =$</p> <p>4) Find $\tan A =$</p>	<p>5) $\sin 75^\circ = \cos$ _____</p> <p>6) $\cos 40^\circ = \sin$ _____</p> <p>7) $\cos 54^\circ = \cos$ _____</p>
---	---	---

8) Find f .

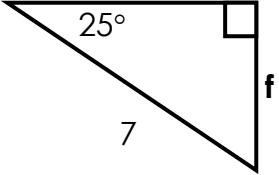

9) Find m .

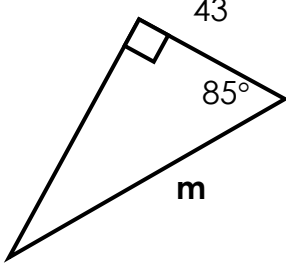

10) Find x .

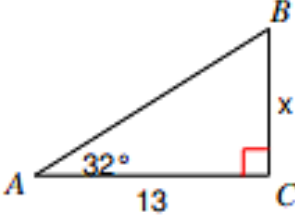

11) Find angle P .

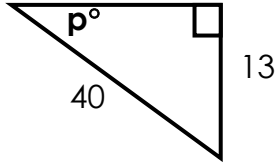

12) Find s .

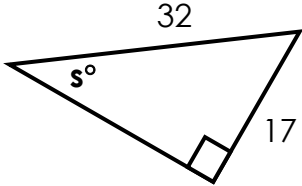

13) Solve for theta.

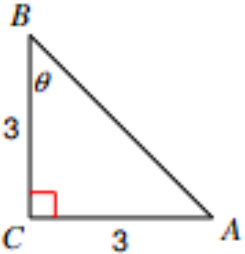

14) From 25 feet away from the base of a building, the angle of elevation from the ground to the top of a building is measured to be 38° . How tall is the building?

15) A kite is 35 feet in the air and the string forms an angle of 62° with the ground. How long is the string?

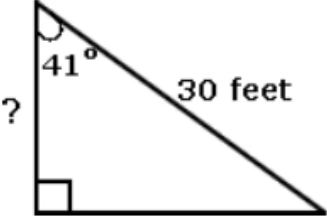
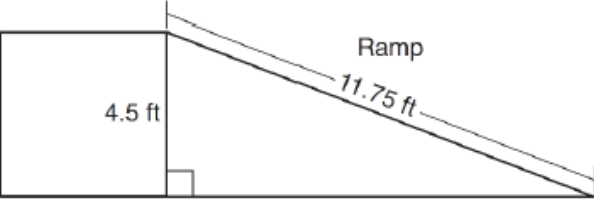
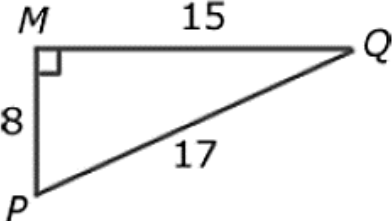
	Answers
<p>1) A 30-foot long escalator forms a 41° angle at the second floor. Which is the closest height of the first floor?</p> <p>A. 20 feet B. 22.6 feet C. 24.5 feet D. 26 feet</p> 	1) _____
<p>2) The diagram below shows a ramp connecting the ground to a loading platform 4.5 feet above the ground. The ramp measures 11.75 feet from the ground to the top of the loading platform. Find the angle of elevation.</p> 	2) _____
<p>3) What is the sine ratio of $\angle P$ in the given triangle?</p> <p>A. $\frac{8}{17}$ B. $\frac{8}{15}$ C. $\frac{15}{17}$ D. $\frac{15}{8}$</p> 	3) _____
<p>4) Which is equal to $\sin 30^\circ$?</p> <p>A. $\cos 30^\circ$ B. $\cos 60^\circ$ C. $\sin 60^\circ$ D. $\sin 70^\circ$</p>	4) _____

5) A rope is tied to the bottom of a hot air balloon as shown below. The rope makes an angle of 35° with the ground and is 75 ft. long. How far is the bottom of the balloon from the ground to the nearest foot?

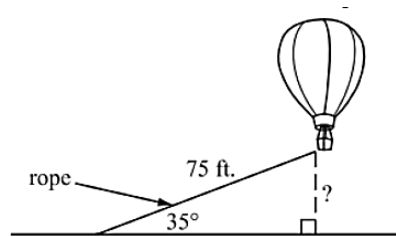

- A. 43 ft.
- B. 53 ft.
- C. 61 ft.
- D. 131 ft.

5) _____

6) The captain of a submarine views an iceberg from his periscope, as shown in the figure below. What is the height of the iceberg to the nearest meter?

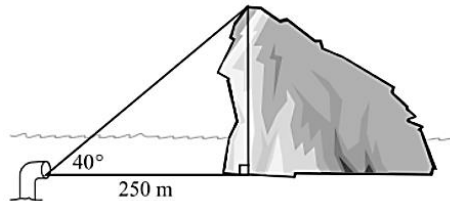

- A. 161 m
- B. 192 m
- C. 210 m
- D. 298 m

6) _____

7) Jeff lives on Oak Street, and Tom lives on Main Street. How much farther, to the nearest yard, is it for Tom to walk down Main Street and turn on Oak Street

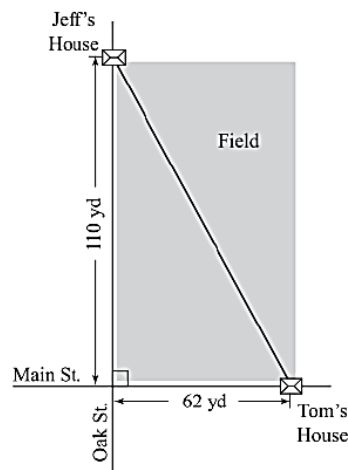

- A. 46 yd
- B. 48 yd
- C. 126 yd
- D. 172 yd

7) _____